



Solutions for

Low Cost Radar Verification Testing with USB Sensor-Based Scalar Network Analysis

Application Note
Radar Measurement Series

Overview

Maximizing radar performance requires thorough analysis and careful optimization of each component and subassembly in the radar system. The effects of signal losses caused by system components in the transmit path are directly characterized by the transmit/receive loss terms in the radar range equation.

Generally, a radar transmitter is the most costly component of the system with the highest power consumption, most stringent cooling requirements, and greatest influence on system performance. Power can be expensive and losses directly reduce the effective power of the radar: As an example, a 1 dB loss has the same impact as a 1 dB reduction in power. When transmitting 1 MW of power, a 1 dB increase to compensate for a loss can be expensive. The more losses can be minimized, the better. Loss measurements are especially important for components such as filters, duplexers, and circulators that are located after the transmit power amplifier or before the low-noise amplifier in the receiver.

Problem

Many instruments are capable of performing basic radar and radar component measurements. Vector network analyzers are often the instrument of choice and are most likely to be required in many R&D and production environments. They are also necessary for specific tests that require calibrated phase measurements. However, these are higher-cost instruments and their availability may be limited to critical test stations. Scalar network analyzers (SNA), such as Agilent's discontinued 8757 series, have long been used as a lower cost-of-test solution for measurements that do not require the measurement of phase.

The SNA capability enables stimulus-response measurements such as gain, insertion loss, frequency response, and return loss. These measurements are used to characterize the transmission or reflection coefficient of radar components such as cables, filters and amplifiers as well as complex subsystems that encompass multiple components, devices and cables.

Examples of stimulus-response measurements include the following:

- 3 dB bandwidth of a bandpass filter
- gain and return loss of an amplifier
- return loss of an antenna
- flatness of a low-pass filter
- frequency response of a cable

For more than 20 years Agilent's 8757 series has been supporting radar test in a wide variety of environments—development, production and operational. The need for further reduction in the cost-of-test has led to an even simpler, lower-cost test solution to perform these basic—but critical—radar measurements.



Agilent Technologies

Solution

The Agilent U2000 Series USB power sensors are compact, light-weight instruments that can perform accurate measurements of RF and microwave power. When used together with a power splitter, a coupler and a signal source, they enable scalar network analysis in addition to power measurements.

Stimulus-response measurements require a source to stimulate the device under test (DUT) and a receiver (in this case, a power sensor) to analyze the DUT's frequency response characteristics. Although other Agilent power meters and sensors may be used for operations above 26.5 GHz, for simplicity, this application note focuses only on the use of USB sensors.

In addition to being a low-cost solution, the USB sensor-based SNA has some attractive features. For example, it offers a wide power range of -60 to $+44$ dBm, depending on the selected power sensor. It provides superior accuracy through a fully calibrated sensor, which provides an absolute measurement accuracy of 3 percent. The frequency response uncertainty is minimized to within ± 0.1 dB and the calibration factor correction is stored in the sensor's memory. Perhaps the most important feature is its dual use: in addition to accurate power measurements, the USB sensors can also be set up to perform accurate scalar power measurements with low overall setup cost. Computer connection and measurement automation are simplified with the available free software and a USB connection.

When U2000 Series USB sensors are used together with a signal source and power splitter or coupler, they can be transformed into an SNA to measure return loss and transmission gain or loss. This application note highlights the features of the U2000 Series for scalar network analysis and addresses transmission, reflection, simultaneous transmission and reflection, and power sweep measurements.

Accurate stimulus-response measurements are performed using the following equipment:

- U2000 Series USB power sensors
- ESG/MXG/PSG signal generators
- broadband couplers
- power splitters

The next section describes three commonly used measurement configurations, provides an overview of the available measurement-automation software, and compares U2000- and 8757-based solutions.

Measurement configurations

As noted previously, U2000 Series USB sensors can be combined with a signal source and power splitter or coupler to measure return loss and transmission gain or loss. This section describes three configurations that can be used to perform transmission, reflection and simultaneous transmission/reflection measurements.

Transmission measurements

A scalar transmission measurement determines the gain or loss of the device under test. With the U2000 Series, two methods can be used to measure transmission: a leveled transmission measurement and a power-leveling transmission measurement.

The worst-case uncertainty for transmission measurements is a combination of three factors: the frequency response, the mismatch uncertainty during calibration and measurement, and the linearity of the sensors. With the USB sensor-based SNA, frequency response error is minimal when corrections are made through the sensor's calibration factors. Frequency response error can be further minimized through normalization or calibration prior to the actual measurement. Linearity error is due to the deviation from the diode's square law region and is typically less than 3 percent. Mismatch uncertainties during the measurement come from the source/DUT input mismatch and the DUT output/sensor mismatch. For a detailed discussion of the uncertainties in transmission measurements when using the USB power sensor SNA, please refer to the application note *Scalar Network Analysis with U2000 Series USB Power Sensors* (publication number 5990-7540EN).¹

Leveled transmission measurement

This configuration adds a power splitter to divide the source power between the DUT and a second power sensor A (Figure 1). With the equal tracking characteristic of a power splitter, the input power of the DUT is equal to the measured power at sensor A. Thus, the transmission coefficient can be calculated as the difference between the power measured at each of the two power sensors.

Compared to the other two methods, the leveled transmission configuration is slightly more expensive due to the addition of the power splitter and second power sensor. However, it offers the advantage of improved accuracy: Any variances in the signal-generator output are present in both sensors and are therefore reduced in the calculation of the transmission coefficient.

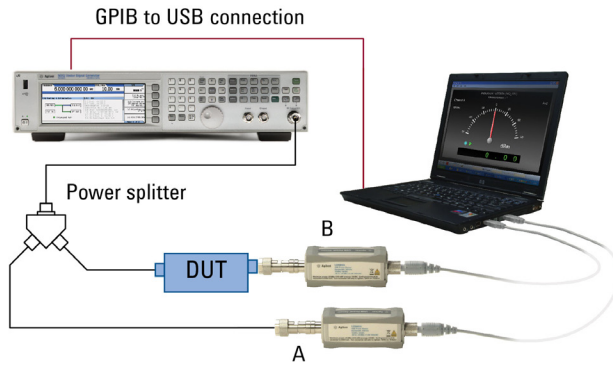

Figure 1. The leveled transmission method offers improved measurement accuracy through a relative measurement between the two power sensors

Post-leveling transmission measurement

This third alternative uses the same hardware as the unleveled transmission measurement, but adds an additional step for calibrating the path loss (Figure 2). In this configuration, the DUT is removed and the sensor measures the output power directly from the source; this data is stored as the calibration factor over a range of frequencies. The DUT is then installed and another set of data is collected at its output. The transmission coefficient is calculated as the difference between the measured power and the stored calibration factor.

The post-leveling configuration is another lower-cost solution because it does not require the power splitter or a second power sensor. Its accuracy should be better than the unleveled configuration because it calibrates out variations of signal generator output power over frequency. Its accuracy may be less than the leveled transmission configuration, depending on the stability of the signal-generator output over time during the interval between the respective calibration and DUT measurements.

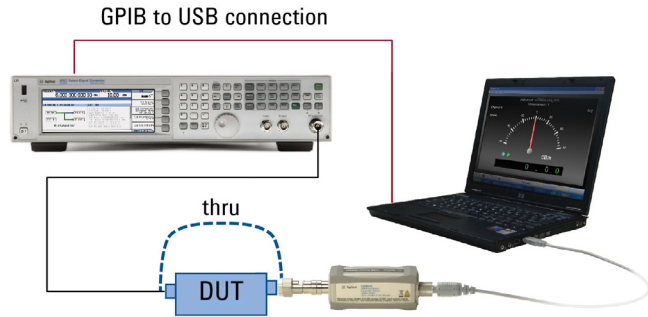

Figure 2. The post-leveling method offers lower cost with improved accuracy

Reflection measurements

A scalar reflection measurement is concerned with how efficiently energy is transferred to a DUT. It is a measure of the amount of mismatch between a DUT and a Z_0 transmission line (Z_0 = characteristic impedance, typically $50\ \Omega$). Not all the energy incident upon a device is absorbed by the device, and the portion not absorbed is reflected back towards the source. The efficiency of energy transfer can be determined by comparing the incident and reflected signals.

Figures 3 and 4 show the reflection measurement calibration and measurement configurations for the USB sensor/signal generator. A reflection measurement requires a signal-separation device such as a power splitter, directional coupler or bridge. The power splitter is used to take a portion of the incident signal for an incident power measurement while the coupler is used to redirect the reflected signal for a reflected power measurement. The DUT is connected at the output of the coupler.

Signal source and power sensor settings such as frequency range and power level should be configured for the measurement. Once the settings have been adjusted, they should not be changed during the course of measurement. This will prevent the introduction of inaccuracies not otherwise present into the measurement system.

To calibrate the system, an open-short calibration is performed to establish a zero dB return loss and store the calibration data into PC. The calibration data is the average of the open and short calibration. The open-short calibration is intended to remove calibration error due to the sum of the directivity and source match. For a detailed discussion of the uncertainties in reflection measurements as they relate to directivity, calibration error and effective source match, please refer to application note *Scalar Network Analysis with U2000 Series USB Power Sensors* (publication number 5990-7540EN).¹

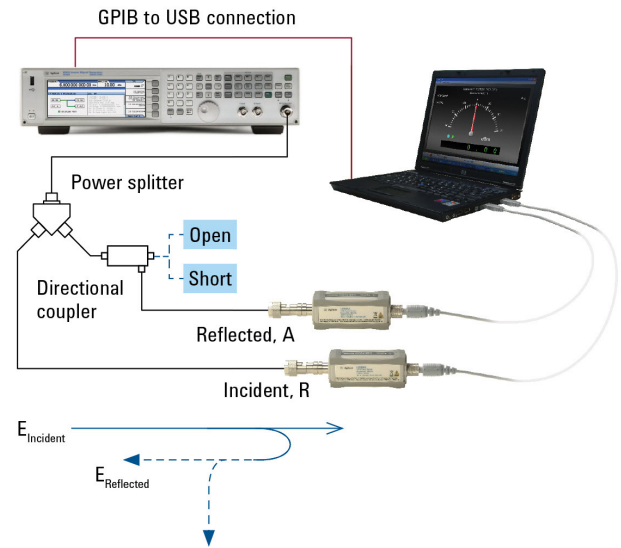

Figure 3. Calibration setup for reflection measurement

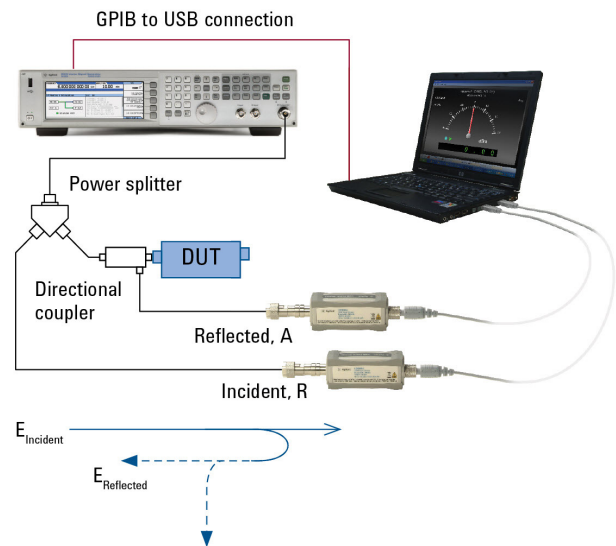

Figure 4. Configuration for reflection measurement

Simultaneous transmission and reflection measurements

It is possible to setup three U2000 Series USB sensors for simultaneous transmission and reflection measurements. Figures 5 and 6 show the calibration and measurement configurations. The power splitter is used to couple a portion of the incident signal for measurement while the coupler is used to redirect the reflected signal for measurement. The DUT is connected to the output of the coupler. Output of the DUT is connected to the third sensor for the measurement of transmitted power. Prior to the measurement, the user is required to perform open, short, and thru calibration. As explained previously, open-short calibration is required for an accurate reflection measurement. Thru calibration is required for accurate transmission measurement to compensate for path loss caused by the additional directional coupler.

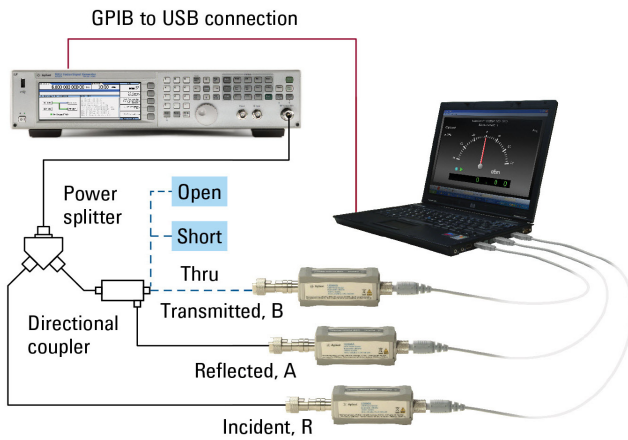

Figure 5. Calibration setup for simultaneous gain and return loss measurements

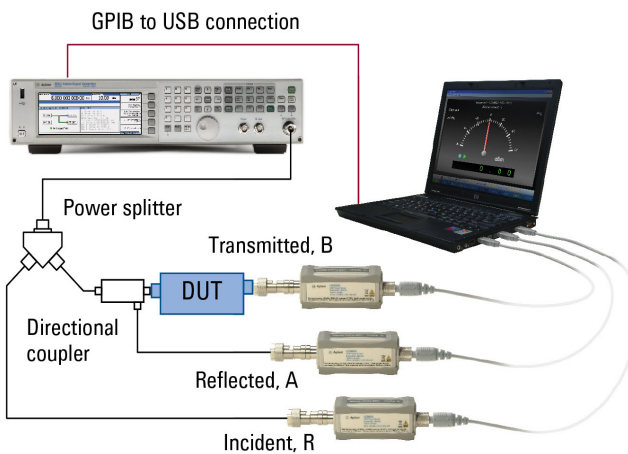

Figure 6. Measurement setup for simultaneous gain and return loss measurements

Optimizing speed in simultaneous measurements

For applications that require fast measurement speed, it is possible to achieve 15 ms per reading using P-Series power meters and sensors with external triggering power or frequency sweep capability. This feature allows the signal source to trigger the power meter via an external TTL signal for measurement capture. After the measurement is captured, the power meter outputs a trigger signal to the signal source to continue with the next step point. This sequence is repeated for every step point. The two-way communication via hard-wired connections between these two instruments helps to reduce communication overhead, resulting in improved overall test time.

Figure 7 illustrates the configuration for this test setup. Please refer to Agilent application note *Maximizing Measurement Speed Using P-Series Power Meters* (publication number 5989-7678EN³) for more details on how to enable this feature.

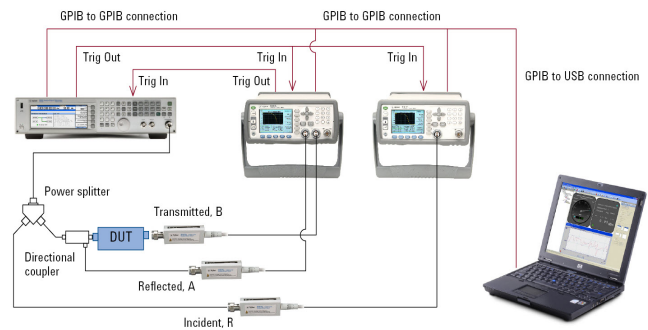

Figure 7. The speed-optimized configuration achieves 15 ms per reading

Performing measurements

Agilent offers free demonstration software, the SNA Tool, for each of the setups shown in this application note. The software is available for download from the Agilent website.² The SNA Tool guides the user through a five-step process for setting up the required configuration, performing any required calibration, and making the measurement. **[Note images come from SW help section]**

Step 1: Start SNA Wizard (shown)

This provides a graphic display of the configuration setup and automatically detects connected instruments. The SNA Tool software is compatible with all Agilent EPM, EPM-P and P-Series power meters as well as USB sensors. In addition it supports Agilent E4438C ESG, N5182A MXG, and E8267D PSG signal generators.

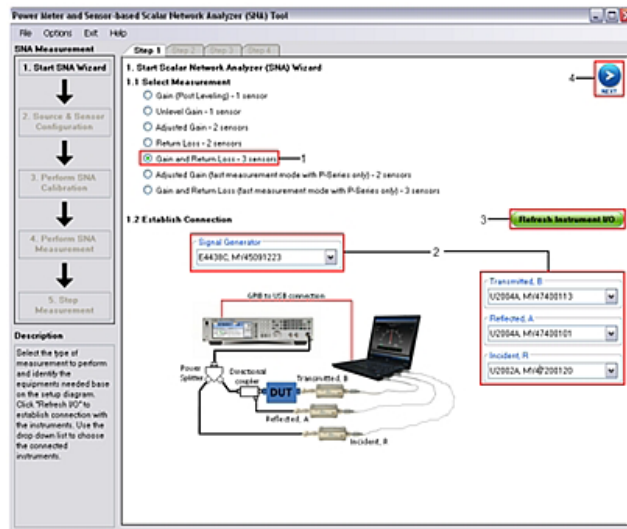

Step 2: Source and sensor configurations:

This allows the user to set required instrument parameters such as frequency range, averaging and triggering.

Step 3: Perform SNA calibration (shown):

This walks the user through whichever calibration is required for the chosen configuration. In this example users are prompted to zero the sensors and then step through the open, short and thru calibration standards measurement.

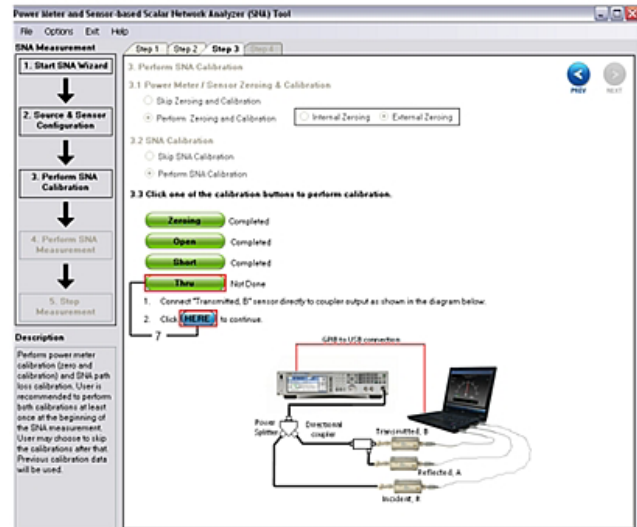

Step 4: Perform SNA measurement

This begins the measurement process.

Step 5: Stop measurement (shown)

This completes the measurement process and is used to analyze the results. Note the tabs across the top allow the user to see the measured power results at each of the sensors as well as the calculated gain and return loss. Markers can be set and the number of traces shown can be varied. The start/stop button (upper right) allows the measured results to be shown in sequence. Trace number and measurement speed are displayed along the bottom. Data may be stored in a user-defined location.

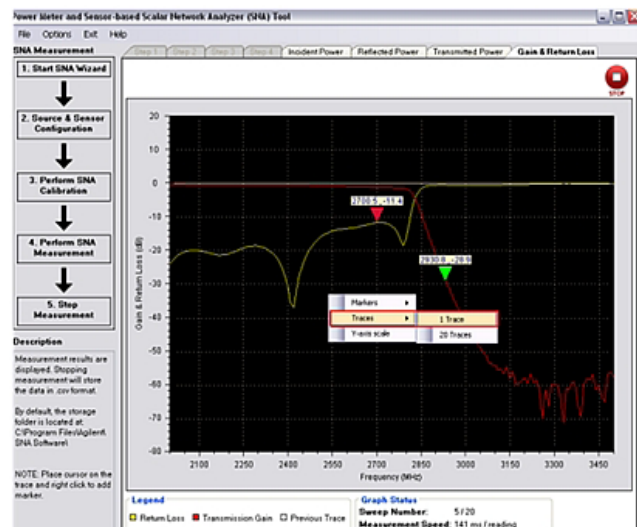

Comparing test equipment

It's interesting to compare the USB sensor-based SNA solution to the well-established 8757 scalar analyzer. Figures 8 and 9 show a set of transmission and reflection measurements made on a low-pass filter. These were performed using each configuration and the overlays reveal the similarities in the results. For example, the broadband transmission result (Figure 8a) highlights an improvement of 8 to 10 dB in the noise floor with the sensor-based solution. In Figure 9a, the delta near 600 MHz is due to directivity error of the coupler used, and this can be improved by using a coupler that provides better directivity.

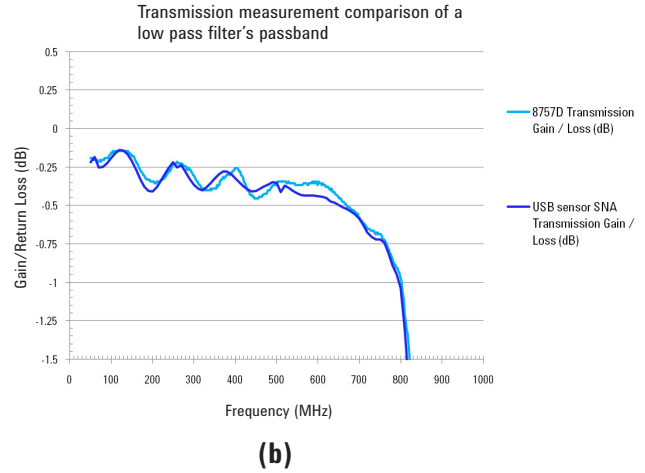
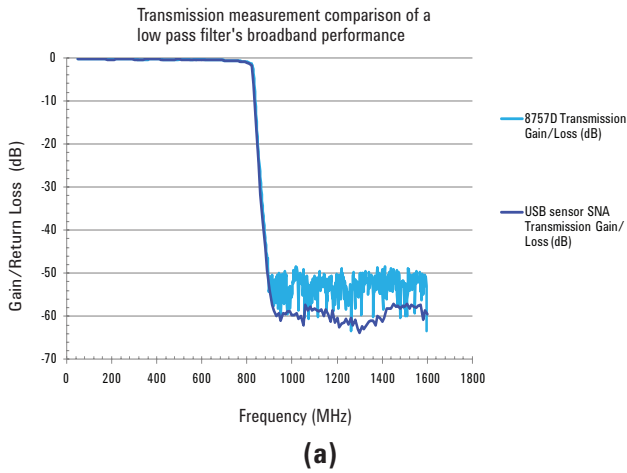

Figure 8. This comparison shows an improved noise floor (a) in the out-of-band transmission performance of a low-pass filter but strong correlation in the passband (b).

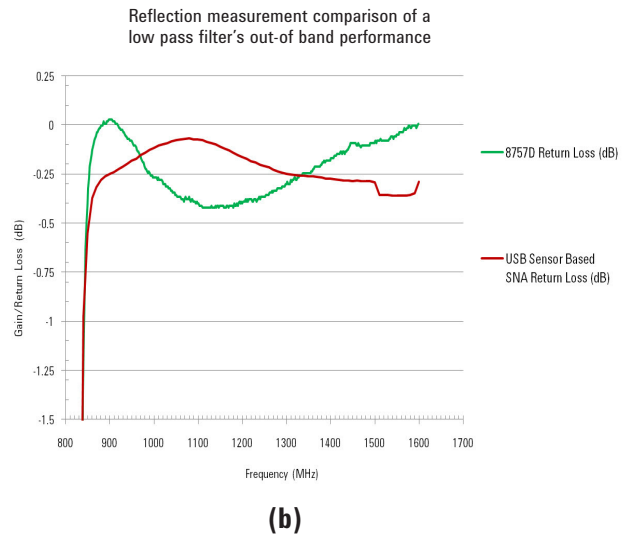
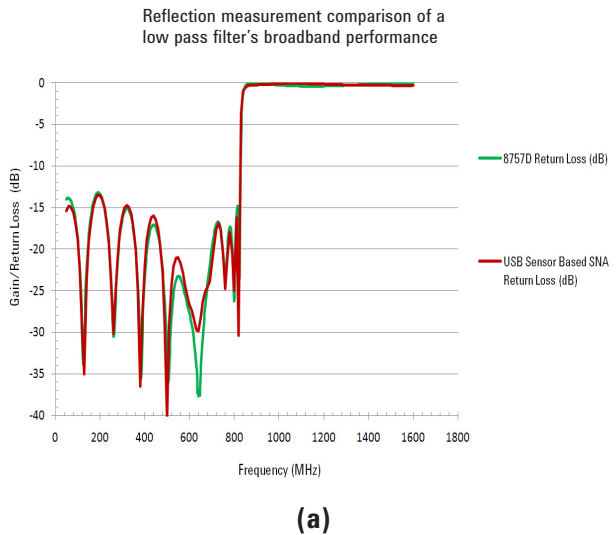

Figure 9. This comparison shows good correlation in the broadband reflection performance of a low-pass filter (a). The out-of-band reflection performance shows good correlation for a scalar measurement (b).

Table 1 provides an overview that compares the different type of instruments capable of performing scalar network analysis. It includes the discontinued Agilent 8757D SNA and the next-generation U2000 series USB sensor-based SNA.

Table 1. Test equipment options for stimulus-response measurements

	8757D, detector and 85027x directional bridge	U2000 Series sensor based SNA
Dynamic range	-60 to +16 dBm	-60 to +20 dBm (U2000A) -50 to +30 dBm (U2000H) -30 to +44 dBm (U2000B)
Frequency range	10 MHz to 110 GHz (detector-dependent)	9 kHz to 26.5 GHz (sensor dependent) (Frequency range up to 110 GHz is available with Agilent power meter and sensor combinations. Refer to 'Ordering Information' section for millimeter wave sensors)
Linearity	Not specified	3%
Directivity	40 dB to 20 GHz 36 dB to 26.5 GHz 30 dB to 40 GHz 25 dB to 50 GHz (bridge-dependent)	Coupler/bridge dependent Example: 86205A bridge 40 dB to 2 GHz 30 dB to 3 GHz 20 dB to 5 GHz 16 dB to 6 GHz
Transmission measurement accuracy	~0.5 to 2.3 dB ¹ (dynamic accuracy + mismatch uncertainty)	~0.3 to 0.5 dB (mismatch uncertainty + linearity)
Reflection measurement accuracy	Mainly depend on the directivity of the coupler/bridge	Mainly depend on the directivity of the coupler/bridge
Return loss of detector/sensor (typical) at 2 GHz 18 GHz	20 dB 20 dB	40 dB 26 dB
Frequency response uncertainty to 18 GHz	±0.35 dB for precision detector (up to ±2 dB for other detectors)	±0.1 dB
Measurement speed	40 to 400 ms per sweep (75 ms for 2 traces with 201 points)	~50 ms per reading (~10 second per sweep for 201 points) ²
Price	8757D (discontinued): \$21,000 Detector: \$1,800 to \$2,600 Total solution (18 GHz): ~\$67,000 (including source) ~\$35,000 (excluding source)	Total solution (18 GHz): ~\$40,000 (including source) ~\$14,000 (excluding source)

1. Extract from 8757D data sheet (literature number 5091-2471E).

2. Speed down to 15 ms per reading is available with Agilent P-Series power meters and sensors with external triggering sweep measurement capability. For details, please refer to "Optimizing Measurement Speed" section.

Summary

For many years, radar test engineers and technicians have used the Agilent 8757 scalar network analyzer as their instrument of choice for scalar measurements. Today, the USB sensor-based SNA offers a very low cost and accurate alternative. For labs that already have a source, the investment is reduced to the purchase of the USB power sensors, a power splitter and a directional coupler.

In addition to general-purpose power measurements, the U2000 Series sensor-based SNA offers the ability to perform accurate transmission and reflection measurements. The USB sensor offers wide dynamic range and provides accuracy up to 3 percent. The frequency response uncertainty is less than 0.1 dB with calibration factor corrections. When used together with a power splitter and coupler, it enables accurate scalar power measurements with low overall setup cost.

Transmission measurements can be easily made with the U2000 Series with the help of the SNA Software Tool. Examples include 3 dB bandwidth of a bandpass filter, gain and return loss of an amplifier, return loss of an antenna, flatness of a low-pass filter, and frequency response of a cable.

References

- ¹ Application Note: *Scalar Network Analysis with U2000 Series USB Power Sensors*, April 8, 2011; publication number 5990-7540EN
- ² Software: SNA Tool, www.agilent.com/find/SNAsoftware_download
- ³ Application Note: *Maximizing Measurement Speed Using P-Series Power Meters*, publication number 5989-7678EN



Agilent Advantage Services is committed to your success throughout your equipment's lifetime. To keep you competitive, we continually invest in tools and processes that speed up calibration and repair and reduce your cost of ownership. You can also use Infoline Web Services to manage equipment and services more effectively. By sharing our measurement and service expertise, we help you create the products that change our world.

www.agilent.com/find/advantageservices



www.agilent.com/quality



Agilent Email Updates

www.agilent.com/find/emailupdates

Get the latest information on the products and applications you select.

www.agilent.com
www.agilent.com/find/AD

For more information on Agilent Technologies' products, applications or services, please contact your local Agilent office. The complete list is available at: www.agilent.com/find/contactus

Americas

Canada	(877) 894 4414
Brazil	(11) 4197 3500
Mexico	01800 5064 800
United States	(800) 829 4444

Asia Pacific

Australia	1 800 629 485
China	800 810 0189
Hong Kong	800 938 693
India	1 800 112 929
Japan	0120 (421) 345
Korea	080 769 0800
Malaysia	1 800 888 848
Singapore	1 800 375 8100
Taiwan	0800 047 866
Other AP Countries	(65) 375 8100

Europe & Middle East

Belgium	32 (0) 2 404 93 40
Denmark	45 70 13 15 15
Finland	358 (0) 10 855 2100
France	0825 010 700*
	*0.125 €/minute
Germany	49 (0) 7031 464 6333
Ireland	1890 924 204
Israel	972-3-9288-504/544
Italy	39 02 92 60 8484
Netherlands	31 (0) 20 547 2111
Spain	34 (91) 631 3300
Sweden	0200-88 22 55
United Kingdom	44 (0) 131 452 0200

For other unlisted countries:

www.agilent.com/find/contactus

Revised: June 8, 2011

Product specifications and descriptions in this document subject to change without notice.

© Agilent Technologies, Inc. 2011
Published in USA, July 28, 2011
5990-7530EN



Agilent Technologies